



AC97 Digital Controller

PRODUCT BRIEF

Overview Features

AC 97 is an audio controller equipped with AC link interface and an 8-bit peripheral bus interface. This core provides a high quality audio solution in combination with audio codec and driver software.

The controller is designed for easy integration into wide range of applications on most ASIC and FPGA technologies.

- ❑ AC97 rev 2.1 compliant
- ❑ Fully synchronous design
- ❑ Supports 8/16/18/20 bit ADC/DAC resolution
- ❑ Supports playback of mono audio sample stream
- ❑ Supports low power, sleep state and wake up modes
- ❑ Configurable FIFO depth and width
- ❑ PIO and DMA channels for FIFO data transfer
- ❑ Option to sample 1/2/4 samples per 32 bits
- ❑ 8 bit wide peripheral bus interface
- ❑ Loop back mode for test purpose

AC 97 Digital Controller

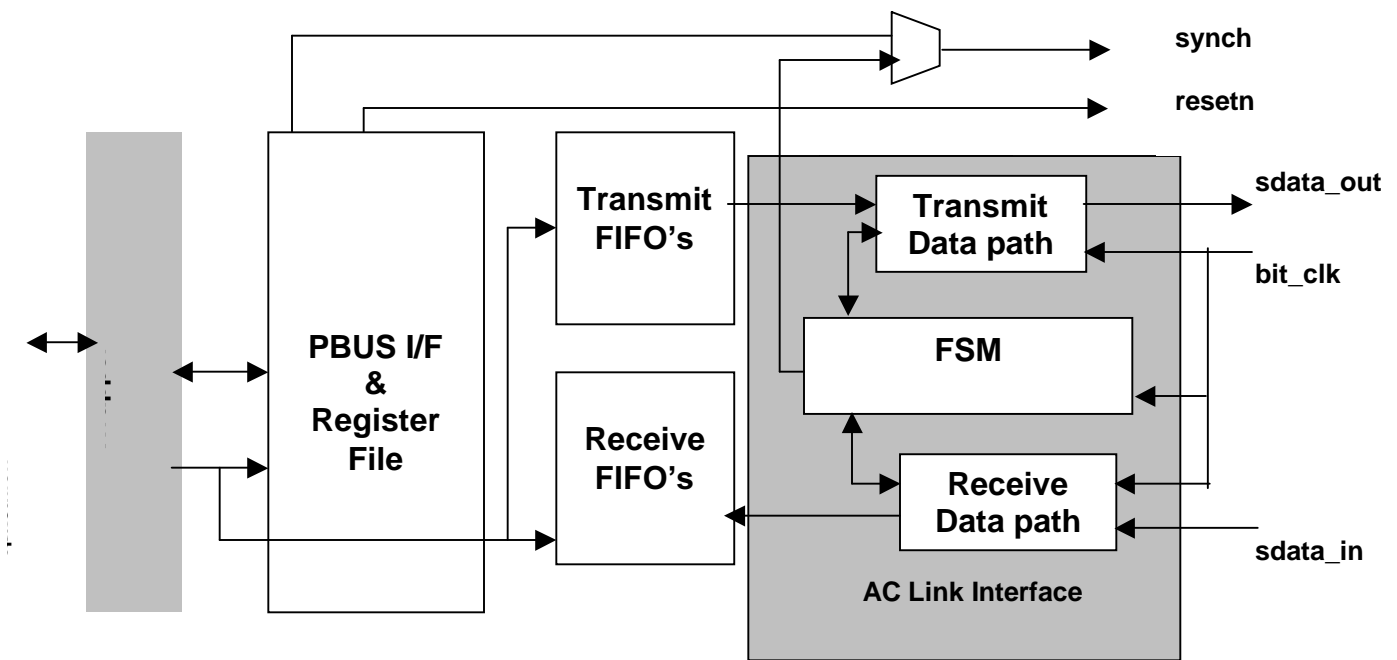



AC97 Digital Controller

Visit: www.gdatech.com

Call: 408.432.3090

Fax: 408.432.0660

Email: ip@gdatech.com

Write: **GDA Technologies**
1010 Rincon Circle
San Jose, CA 95151

Status: Gold [Silicon Proven]

Availability: Now

Language: Verilog

Synthesis: Synopsys DC

Simulation: Verilog XL or NC Verilog

Technology: 0.18 micron

Specifications

Configurable Options

- FIFO width and depth
- Input and output slots
- Number of FIFO's
- ADC/DAC Resolution

Design Attributes

- Fully synchronous
- Technology independent
- Loop back mode for testing
- PIO and DMA channels for FIFO data transfer
- Active low asynchronous reset
- Most of the logic functions at 12.2 Mhz
- 8 bit wide peripheral bus interface

Product Package

- Verilog RTL
- Verification environment
- Testcases
- Synthesis environment/scripts

Documentation

- Design
- User guide

GDA Technologies reserves the right to change this document without prior notice and disclaim all warranties. It is the recipient's duty to confirm with GDA Technologies' Engineering Department specifications before proceeding with a product design. This document is confidential and should not be reproduced without GDA Technologies approval.

GDA Technologies, Hypertransport Xxxx Core, HyperXxxx and the GDA Technologies logo are trademarks of GDA Technologies, Inc.
Patents and Patents pending.

©2002 GDA Technologies, Inc. San Jose, CA. All rights reserved.

Month 200x Version 1.0

www.gdatech.com



GDA Technologies, Inc
accelerate your innovation™